



ARMO-R

SMOKE AND HEAT EXHAUST FANS / Roof



Axial roof fans are used in pressurization fan, fresh air fan and smoke exhaust fan applications. The enclosure is fire resistant and designed according to the noise standard. Smoke evacuation fans are fire resistant.

General Features

- It has EN 12101-3 and Ce certificates.
- 2 hours continuous operation at 400 C and 300 C
- There is a wide product range from 400 mm to 1250 mm.

Rotor Features

- Fire resistant aluminum alloy casting blades and fan hub.
- Has the ability to work one-way and two-way. The blades are specially designed according to each direction type.
- There is no aerodynamic loss in the case of reversible wing type operation.
- Wings are airfoil and provide high aerodynamic performance in both unidirectional and bidirectional vanes.
- Wing angles are adjustable. In this way, smoke discharge fans can be demanded at different flow rates and pressures.
- The fan part of

the fan is dynamically balanced according to ISO 1940 and there is no eccentricity during the operation of the fan.

Body Features

- Fan body is steel sheet. Body is hot dip galvanized and corrosion resistant.
- It has short type body and long type body types.

Motor Features

- Offers 2.4 and 6-pole motors
- The motors are IP 55 class and Class-H insulated.
- All electric motor models are approved for continuous operation (S1) and Emergency operation (S2).

Ease of Maintenance

A maintenance cover is provided to ensure easy maintenance.

Usage Areas

Roof type Axial fans are used in pressurization fan, fresh air fan and smoke exhaust fan applications.

Technical Drawing and Tables

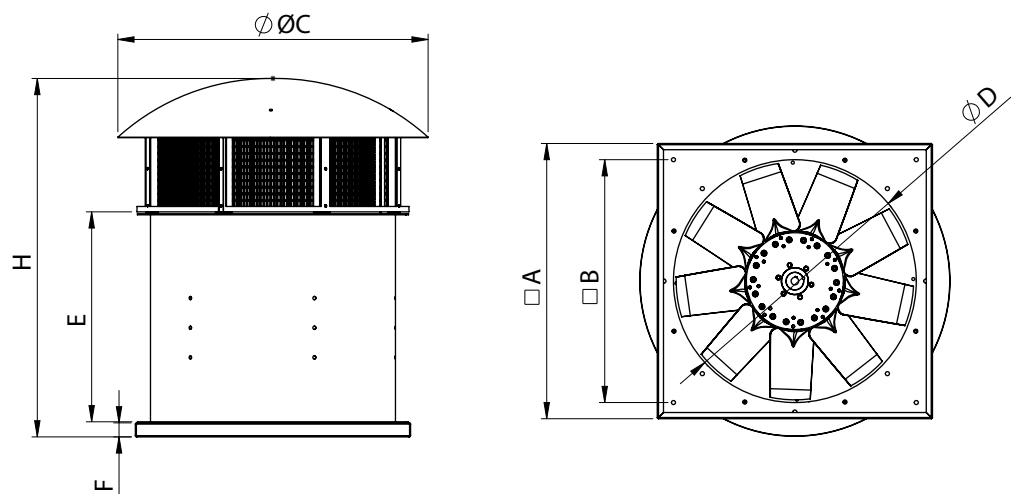

TYPE	A	B	C	D	E	H	F
ARMO-R 400	600	495	702	400	474	880	50
ARMO-R 450	650	545	702	450	474	880	50
ARMO-R 500	650	545	842	500	580	1030	50
ARMO-R 560	685	605	842	560	580	1030	50
ARMO-R 630	780	637	1130	630	600	1160	50
ARMO-R 710	830	710	1130	800	700	1300	50
ARMO-R 800	920	800	1130	800	700	1300	50
ARMO-R 900	1020	900	1130	900	775	1375	50
ARMO-R 1000	1130	1030	1430	1000	850	1450	50
ARMO-R 1250	1430	1350	1430	1250	950	1550	50

Dimensions are in (mm)



2 POLE TYPE	SPEED	DIAMETER	POWER	CURRENT	AIR FLOW	WING ANGLE
	r.p.m	mm	kW	230V - 400V	m ³ /h	
ARMO-R / 400-6 / 0,75 - 2A	2900	400	0,75	1,6	5250	16°
ARMO-R / 400-6 / 1,1 - 2A	2900	400	1,1	2,3	6904	22°
ARMO-R / 400-6 / 1,5 - 2A	2900	400	1,5	3,4	8978	30°
ARMO-R / 400-6 / 2,2 - 2A	2900	400	2,2	4,48	9975	34°
ARMO-R / 450-6 / 1,1 - 2A	2900	450	1,1	2,3	6248	10°
ARMO-R / 450-6 / 1,5 - 2A	2900	450	1,5	3,4	8610	16°
ARMO-R / 450-6 / 2,2 - 2A	2900	450	2,2	4,48	11970	24°
ARMO-R / 450-6 / 3 - 2A	2900	450	3	6	13545	28°
ARMO-R / 500-6 / 2,2 - 2A	2900	500	2,2	4,48	11000	14°
ARMO-R / 500-6 / 3 - 2A	2900	500	3	6	14595	20°
ARMO-R / 500-6 / 4 - 2A	2900	500	4	7,4	17325	26°
ARMO-R / 500-6 / 5,5 - 2A	2900	500	5,5	11	18375	28°
ARMO-R / 560-6 / 4 - 2A	2900	560	4	7,4	17850	14°
ARMO-R / 560-6 / 5,5 - 2A	2900	560	5,5	11	22313	20°
ARMO-R / 560-6 / 7,5 - 2A	2800	560	7,5	13,6	25725	24°
ARMO-R / 630-6 / 5,5 - 2A	2900	630	5,5	11	20475	10°
ARMO-R / 630-6 / 7,5 - 2A	2800	630	7,5	13,6	27300	16°

4 POLE TYPE	SPEED	DIAMETER	POWER	CURRENT	AIR FLOW	WING ANGLE
	r.p.m	mm	kW	230V - 400V	m ³ /h	
ARMO-R / 500-6 / 0,55 - 4A	1415	500	0,55	1,6	8715	26
ARMO-R / 500-6 / 0,75 - 4A	1350	500	0,75	2,1	10290	32
ARMO-R / 500-6 / 1,1 - 4A	1400	500	1,1	2,6	12600	38
ARMO-R / 560-6 / 0,55 - 4A	1415	560	0,55	1,6	9870	16
ARMO-R / 560-6 / 0,75 - 4A	1350	560	0,75	2,1	12075	22
ARMO-R / 560-6 / 1,1 - 4A	1400	560	1,1	2,6	13860	26
ARMO-R / 560-6 / 1,5 - 4A	1405	560	1,5	3,5	15750	32
ARMO-R / 560-6 / 2,2 - 4A	1410	560	2,2	5	17850	38
ARMO-R / 630-6 / 0,75 - 4A	1350	630	0,75	2,1	10605	10
ARMO-R / 630-6 / 1,1 - 4A	1400	630	1,1	2,6	16275	20
ARMO-R / 630-6 / 1,5 - 4A	1405	630	1,5	3,5	18375	24
ARMO-R / 630-6 / 2,2 - 4A	1410	630	2,2	5	21525	30
ARMO-R / 630-6 / 3 - 4A	1410	630	3	6,6	24150	36
ARMO-R / 630-6 / 4 - 4A	1500	630	4	8,2	25200	38
ARMO-R / 710-3 / 0,75 - 4A	1350	710	0,75	2,1	14175	10
ARMO-R / 710-3 / 1,1 - 4A	1400	710	1,1	2,6	18375	16
ARMO-R / 710-3 / 1,5 - 4A	1405	710	1,5	3,5	21000	20
ARMO-R / 710-3 / 2,2 - 4A	1410	710	2,2	5	24413	26
ARMO-R / 710-3 / 3 - 4A	1410	710	3	6,6	27825	32
ARMO-R / 710-6 / 1,1 - 4A	1400	710	1,1	2,6	16275	12
ARMO-R / 710-6 / 1,5 - 4A	1405	710	1,5	3,5	20475	18
ARMO-R / 710-6 / 2,2 - 4A	1410	710	2,2	5	23625	22
ARMO-R / 710-6 / 3 - 4A	1410	710	3	6,6	28350	28
ARMO-R / 710-6 / 4 - 4A	1415	710	4	8,2	31500	32
ARMO-R / 800-6 / 2,2 - 4A	1410	800	2,2	5	24150	14
ARMO-R / 800-6 / 3 - 4A	1410	800	3	6,6	30450	20
ARMO-R / 800-6 / 4 - 4A	1415	800	4	8,2	32550	22
ARMO-R / 800-6 / 5,5 - 4A	1430	800	5,5	11,2	38850	28
ARMO-R / 800-6 / 7,5 - 4A	1440	800	7,5	15,4	42525	32
ARMO-R / 800-9 / 2,2 - 4A	1410	800	2,2	5	16275	10
ARMO-R / 800-9 / 3 - 4A	1410	800	3	6,6	21525	14
ARMO-R / 800-9 / 4 - 4A	1415	800	4	8,2	29400	20
ARMO-R / 800-9 / 5,5 - 4A	1430	800	5,5	11,2	36488	26
ARMO-R / 800-9 / 7,5 - 4A	1440	800	7,5	15,4	40950	30
ARMO-R / 800-9 / 11 - 4A	1450	800	11	21	43050	32
ARMO-R / 900-6 / 4 - 4A	1415	900	4	8,2	31500	12
ARMO-R / 900-6 / 5,5 - 4A	1430	900	5,5	11,2	38850	16
ARMO-R / 900-6 / 7,5 - 4A	1440	900	7,5	15,4	47775	22
ARMO-R / 900-6 / 11 - 4A	1450	900	11	21	56700	28
ARMO-R / 900-6 / 15 - 4A	1450	900	15	29,3	60900	32
ARMO-R / 900-9 / 4 - 4A	1415	900	4	8,2	26775	10
ARMO-R / 900-9 / 5,5 - 4A	1430	900	5,5	11,2	34125	14
ARMO-R / 900-9 / 7,5 - 4A	1440	900	7,5	15,4	41213	18
ARMO-R / 900-9 / 11 - 4A	1450	900	11	21	54600	26
ARMO-R / 900-9 / 15 - 4A	1450	900	15	29,3	63525	32
ARMO-R / 1000-6 / 5,5 - 4A	1430	1000	5,5	11,2	38850	12
ARMO-R / 1000-6 / 7,5 - 4A	1440	1000	7,5	15,4	47775	18
ARMO-R / 1000-6 / 11 - 4A	1450	1000	11	21	56700	22
ARMO-R / 1000-6 / 15 - 4A	1450	1000	15	29,3	60900	28
ARMO-R / 1000-6 / 18,5 - 4A	1455	1000	18,5	34,5	56700	32
ARMO-R / 1000-9 / 7,5 - 4A	1440	1000	7,5	15,4	43050	12
ARMO-R / 1000-9 / 11 - 4A	1450	1000	11	21	55650	18
ARMO-R / 1000-9 / 15 - 4A	1450	1000	15	29,3	69300	24
ARMO-R / 1000-9 / 18,5 - 4A	1455	1000	18,5	34,5	77700	28
ARMO-R / 1000-9 / 22 - 4A	1460	1000	22	42,5	81900	30
ARMO-R / 1000-9 / 30 - 4A	1460	1000	30	55	86100	32
ARMO-R / 1250-6 / 15 - 4A	1450	1250	15	29,3	90300	12
ARMO-R / 1250-6 / 18,5 - 4A	1455	1250	18,5	34,5	103950	16
ARMO-R / 1250-6 / 22 - 4A	1460	1250	22	42,5	109725	18
ARMO-R / 1250-6 / 30 - 4A	1460	1250	30	55	122850	22
ARMO-R / 1250-6 / 37 - 4A	1470	1250	37	67	136500	26
ARMO-R / 1250-6 / 45 - 4A	1475	1250	45	80	155400	32
ARMO-R / 1250-9 / 18,5 - 4A	1455	1250	18,5	34,5	89250	12
ARMO-R / 1250-9 / 22 - 4A	1460	1250	22	42,5	97650	14
ARMO-R / 1250-9 / 30 - 4A	1460	1250	30	55	114975	18
ARMO-R / 1250-9 / 37 - 4A	1470	1250	37	67	131250	22
ARMO-R / 1250-9 / 45 - 4A	1475	1250	45	80	138600	24

6 POLE TYPE	SPEED	DIAMETER	POWER	CURRENT	AIR FLOW	WING ANGLE
	r.p.m	mm	kW	230V - 400V	m ³ /h	
ARMO-R / 500-6 / 0,37 - 6A	900	500	0,37	1,1	8400	38
ARMO-R / 560-6 / 0,37 - 6A	900	560	0,37	1,1	10500	32
ARMO-R / 560-6 / 0,55 - 6A	930	560	0,55	1,5	11760	38
ARMO-R / 630-6 / 0,37 - 6A	900	630	0,37	1,1	11576	22
ARMO-R / 630-6 / 0,55 - 6A	930	630	0,55	1,5	13650	28
ARMO-R / 630-6 / 0,75 - 6A	945	630	0,75	2	14963	32
ARMO-R / 630-6 / 1,1 - 6A	945	630	1,1	2,9	16800	38
ARMO-R / 710-3 / 0,37 - 6A	900	710	0,37	1,1	13125	18
ARMO-R / 710-3 / 0,55 - 6A	930	710	0,55	1,5	16538	26
ARMO-R / 710-3 / 0,75 - 6A	945	710	0,75	2	18900	32
ARMO-R / 710-6 / 1,1 - 6A	945	710	1,1	2,9	11025	12
ARMO-R / 710-6 / 1,5 - 6A	945	710	1,5	3,6	13000	16
ARMO-R / 710-6 / 2,2 - 6A	950	710	2,2	5,4	13750	22
ARMO-R / 710-6 / 3 - 6A	950	710	3	6,9	18900	28
ARMO-R / 710-6 / 4 - 6A	955	710	4	9	21000	32
ARMO-R / 800-6 / 0,55 - 6A	930	800	0,55		13125	10
ARMO-R / 800-6 / 1,1 - 6A	945	800	1,1	2,9	22050	22
ARMO-R / 800-6 / 1,5 - 6A	945	800	1,5	3,6	25200	26
ARMO-R / 800-6 / 2,2 - 6A	950	800	2,2	5,4	28350	32
ARMO-R / 800-9 / 0,75 - 6A	945	800	0,75	2	14700	14
ARMO-R / 800-9 / 1,1 - 6A	945	800	1,1	2,9	19950	20
ARMO-R / 800-9 / 1,5 - 6A	945	800	1,5	3,6	23100	24
ARMO-R / 800-9 / 2,2 - 6A	950	800	2,2	5,4	27300	30
ARMO-R / 800-9 / 3 - 6A	950	800	3	6,9	28350	32
ARMO-R / 900-6 / 1,1 - 6A	945	900	1,1	2,9	23100	14
ARMO-R / 900-6 / 1,5 - 6A	945	900	1,5	3,6	25200	16
ARMO-R / 900-6 / 2,2 - 6A	950	900	2,2	5,4	31500	22
ARMO-R / 900-6 / 3 - 6A	950	900	3	6,9	36750	28
ARMO-R / 900-6 / 4 - 6A	955	900	4	9	40950	32
ARMO-R / 900-9 / 1,5 - 6A	945	900	1,5	3,6	23100	14
ARMO-R / 900-9 / 2,2 - 6A	950	900	2,2	5,4	27300	20
ARMO-R / 900-9 / 3 - 6A	950	900	3	6,9	35700	24
ARMO-R / 900-9 / 4 - 6A	955	900	4	9	39900	30
ARMO-R / 900-9 / 5,5 - 6A	985	900	5,5	12,3	43050	32
ARMO-R / 1000-6 / 1,5 - 6A	945	1000	1,5	3,6	26250	10
ARMO-R / 1000-6 / 2,2 - 6A	950	1000	2,2	5,4	34650	16
ARMO-R / 1000-6 / 3 - 6A	950	1000	3	6,9	44100	22
ARMO-R / 1000-6 / 4 - 6A	955	1000	4	9	49350	26
ARMO-R / 1000-6 / 5,5 - 6A	985	1000	5,5	12,3	55650	32
ARMO-R / 1000-9 / 2,2 - 6A	950	1000	2,2	5,4	32550	14
ARMO-R / 1000-9 / 3 - 6A	950	1000	3	6,9	39900	20
ARMO-R / 1000-9 / 4 - 6A	955	1000	4	9	43050	22
ARMO-R / 1000-9 / 5,5 - 6A	985	1000	5,5	12,3	52500	28
ARMO-R / 1000-9 / 7,5 - 6A	960	1000	7,5	15	57750	32
ARMO-R / 1250-6 / 4 - 6A	955	1250	4	9	60900	12
ARMO-R / 1250-6 / 5,5 - 6A	985	1250	5,5	12,3	63300	16
ARMO-R / 1250-6 / 7,5 - 6A	960	1250	7,5	15	76650	20
ARMO-R / 1250-6 / 11 - 6A	960	1250	11	22	92400	26
ARMO-R / 1250-6 / 15 - 6A	965	1250	15	29	105000	32
ARMO-R / 1250-9 / 7,5 - 6A	960	1250	7,5	15	73500	16
ARMO-R / 1250-9 / 11 - 6A	960	1250	11	22	88200	22
ARMO-R / 1250-9 / 15 - 6A	965	1250	15	29	105000	28
ARMO-R / 1250-9 / 18,5 - 6A	970	1250	18,5	36,5	115500	32

Accessories



